

# Directional spool valves, pilot-operated, with electro-hydraulic actuation

## Type H-4WEH ...XD

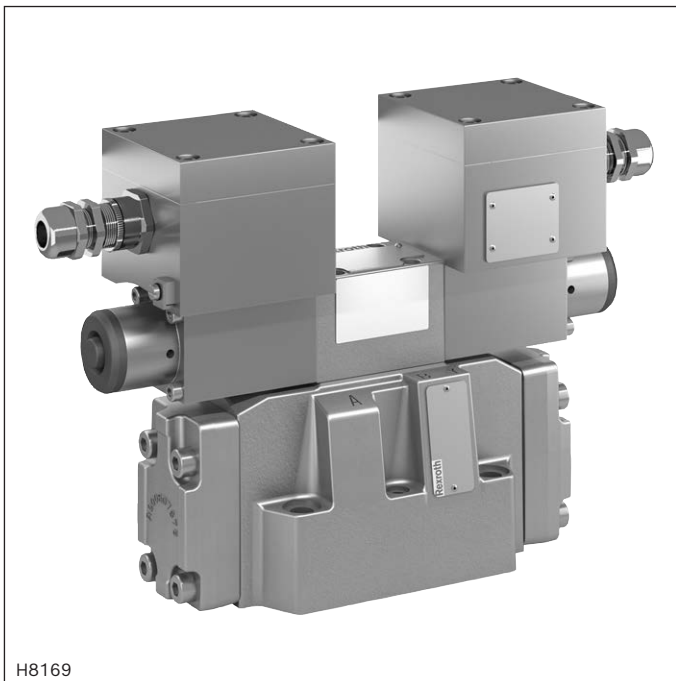

H8169

- ▶ Size 10 ... 32
- ▶ Component series 4X; 6X; 7X
- ▶ Maximum operating pressure 350 bar
- ▶ Maximum flow 1100 l/min



### ATEX units For potentially explosive atmospheres



#### Information on explosion protection:

- ▶ Area of application in accordance with the Explosion Protection Directive 2014/34/EU:  
**I M2; II 2G**
- ▶ Type of protection valve:
  - Ex h I Mb X according to EN 80079-38
  - Ex h IIC T4 Gb X according to EN 80079-36
- ▶ Type of protection valve solenoids:
  - Ex db I Mb according to EN 60079-1
  - Ex db IIC T4 Gb according to EN 60079-1
- ▶ Valve solenoid certified according to IECEx

### Features

- ▶ 4/3 or 4/2-way version
- ▶ For intended use in potentially explosive atmosphere
- ▶ Internal or external pilot control
- ▶ Subplate mounting
- ▶ Porting pattern according to ISO 4401
- ▶ Spring centering, spring end position or hydraulic end position
- ▶ Wet-pin DC solenoids
- ▶ Manual override
- ▶ Electrical connection as individual connection with cable gland
- ▶ Switching time adjustment, optional
- ▶ Preload valve in channel P of the main valve, optional

### Contents

Features	1
Ordering code	2, 3
Symbols	4 ... 7
Function, section	8
Pilot oil supply	9
Technical data	10 ... 12
Switching times	13
Characteristic curves, performance limits	14 ... 20
Dimensions	21 ... 25
Switching time adjustment	26
Pressure reducing valve "D3"	26
Preload valve	26
Electrical connection	27, 28
Further information	28

 **Notice:** The documentation version with which the product was supplied is valid.

## Ordering code

01	02	03	04	05	06	07	08	09	10	11	12	13	14	15	16	17	18	19
<b>H</b>	<b>-</b>	<b>4</b>	<b>WEH</b>				<b>/</b>		<b>6B</b>	<b>G24</b>	<b>N</b>	<b>XD</b>			<b>Z2</b>			

01	Up to 350 bar	<b>H</b>
----	---------------	----------

02	4-way version	<b>4</b>
----	---------------	----------

### Type of actuation

03	Electro-hydraulic	<b>WEH</b>
----	-------------------	------------

### Size

04	NG10	<b>10</b>
	NG16	<b>16</b>
	NG25	<b>25</b>
	NG32	<b>32</b>

### Control spool return in main valve

05	By springs	<b>no code</b>
	Hydraulic <sup>1)</sup>	<b>H</b>

06	Symbols; possible versions see page 4 and 5	
----	---	--

07	Component series 40 ... 49 (40 ... 49: unchanged installation and connection dimensions) – NG10	<b>4X</b>
	Component series 60 ... 69 (60 ... 69: unchanged installation and connection dimensions) – NG25 and NG32	<b>6X</b>
	Component series 70 ... 79 (70 ... 79: unchanged installation and connection dimensions) – NG16	<b>7X</b>

**Control spool return in the pilot control valve** with 2 spool positions and 2 solenoids  
(only possible with symbols C, D, K, Z and hydraulic control spool return in the main valve)

08	<b>With</b> spring return	<b>no code</b>
	<b>Without</b> spring return	<b>O</b>
	<b>Without</b> spring return with detent	<b>OF</b>

### Pilot control valve

09	High-power valve	<b>6B</b>
----	------------------	-----------

10	Direct voltage 24 V	<b>G24</b>
----	---------------------	------------

11	<b>With</b> manual override	<b>N</b>
----	-----------------------------	----------

### Explosion protection

12	"Flameproof enclosure"	<b>XD</b>
	For details, see information on the explosion protection, page 12	

### Pilot oil supply

13	External pilot oil supply, external pilot oil return <sup>2)</sup>	<b>no code</b>
	Internal pilot oil supply, external pilot oil return <sup>3)</sup>	<b>E</b>
	Internal pilot oil supply, internal pilot oil return <sup>3)</sup>	<b>ET</b>
	External pilot oil supply, internal pilot oil return <sup>2)</sup>	<b>T</b>

### Switching time adjustment

14	<b>Without</b> switching time adjustment	<b>no code</b>
	Switching time adjustment for supply control	<b>S</b>
	Switching time adjustment for discharge control	<b>S2</b>

### Electrical connection

15	Solenoid with terminal box and cable gland	<b>Z2</b>
	For details of electrical connections, see page 27 and 28	

## Ordering code

01	02	03	04	05	06	07	08	09	10	11	12	13	14	15	16	17	18	19
H	-	4	WEH				/		6B	G24	N	XD			Z2			

### Throttle insert

16	Without throttle insert	no code
	Throttle Ø 0.8 mm	B08
	Throttle Ø 1.0 mm	B10
	Throttle Ø 1.2 mm	B12
	Throttle Ø 1.5 mm	B15

### Preload valve (not for NG10)

17	Without preload valve	no code
	With preload valve ( $p_0 = 4.5$ bar)	P4,5

18	Without pressure reducing valve	no code
	With pressure reducing valve	D3 <sup>4)</sup>

### Seal material (observe compatibility of seals with hydraulic fluid used, see page 11)

19	NBR seals	no code
	FKM seals	V

- 1) 2 spool positions (hydraulic end position): only symbols C, D, K, Z, Y
- 2) Pilot oil supply X or return Y **external**:
  - ▶ Maximum pilot pressure: see page 10.
  - ▶ At higher pilot pressure, version "**D3**" must be used.
- 3) Pilot oil supply **internal** (versions "ET" and "E"):
  - ▶ Minimum pilot pressure: see page 10.
  - ▶ Maximum pilot pressure: see page 10.
  - ▶ In order to prevent inadmissibly high pressure peaks, a **throttle insert "B10"** has to be provided in port P of the pilot control valve (see page 9).
  - ▶ Version "**D3**" must be used.
- 4) In connection with throttle insert "**B10**"



#### Notice:

The manual override cannot be assigned a safety function. It may only be actuated up to a tank pressure of 50 bar.

**Symbols:** 2 spool positions

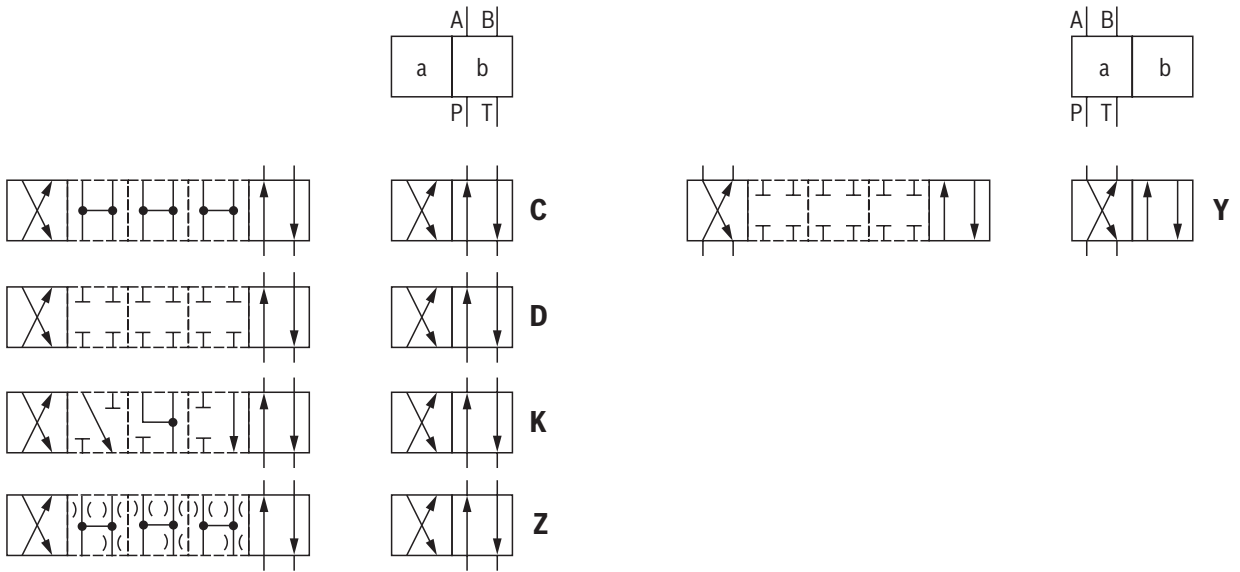

Symbol	Ordering code	Type of actuation
	Control spool return	Type WEH (electro-hydraulic)
C, D, K, Z	../..	
	..H../..	
	..H../O	
	..H../OF	
Y	../..	
	..H../..	

**Symbols: 3 spool positions**

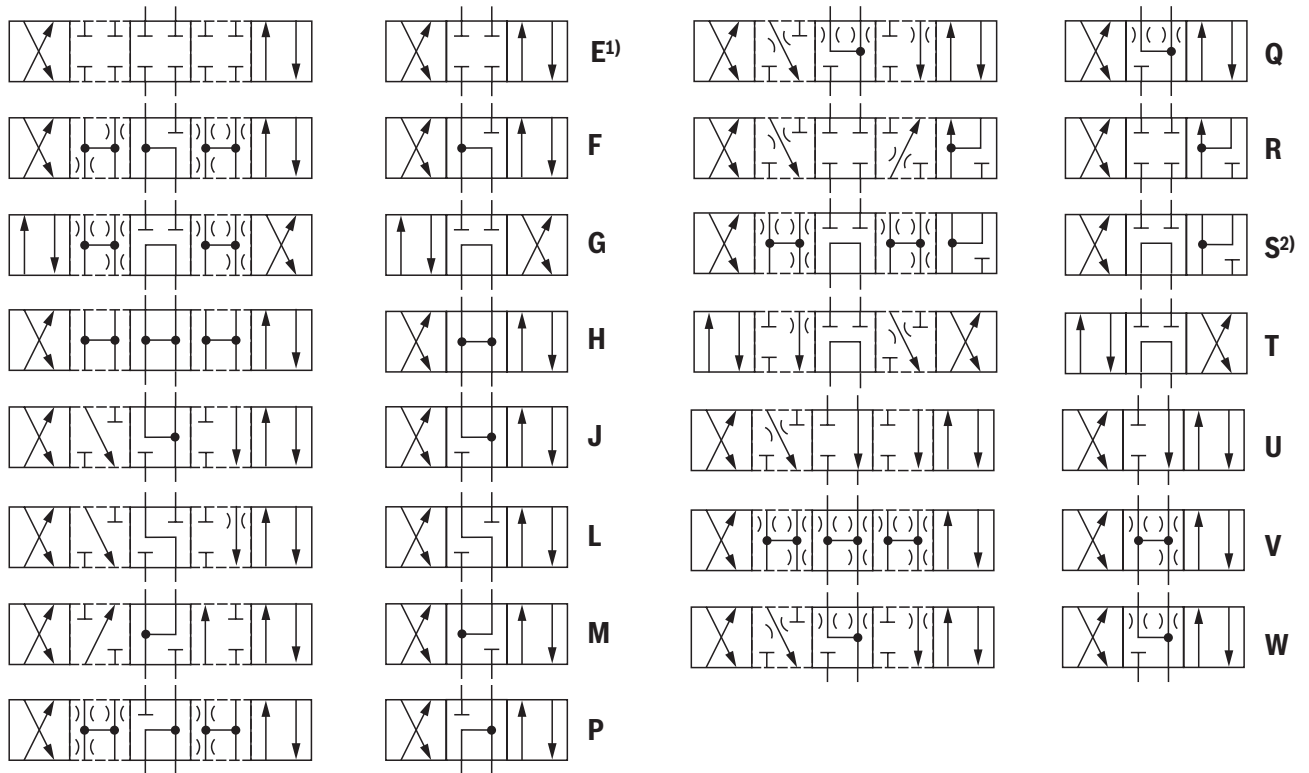

Symbol	Ordering code		Type of actuation
	Actuating side	Control spool return	Type WEH (electro-hydraulic)
E, F, G, H, J, L, M, P, Q, R, S, T, U, V, W		../..	
	.A		
	.B		

- 1) **Example:**  
Symbol E with actuating side "a" → ordering code ..EA..
- 2) Symbol S only for NG16

**Notice:**  
Representation according to DIN ISO 1219-1.  
Hydraulic interim positions are shown by dashes.

**Symbols:** Valve with 2 spool positions

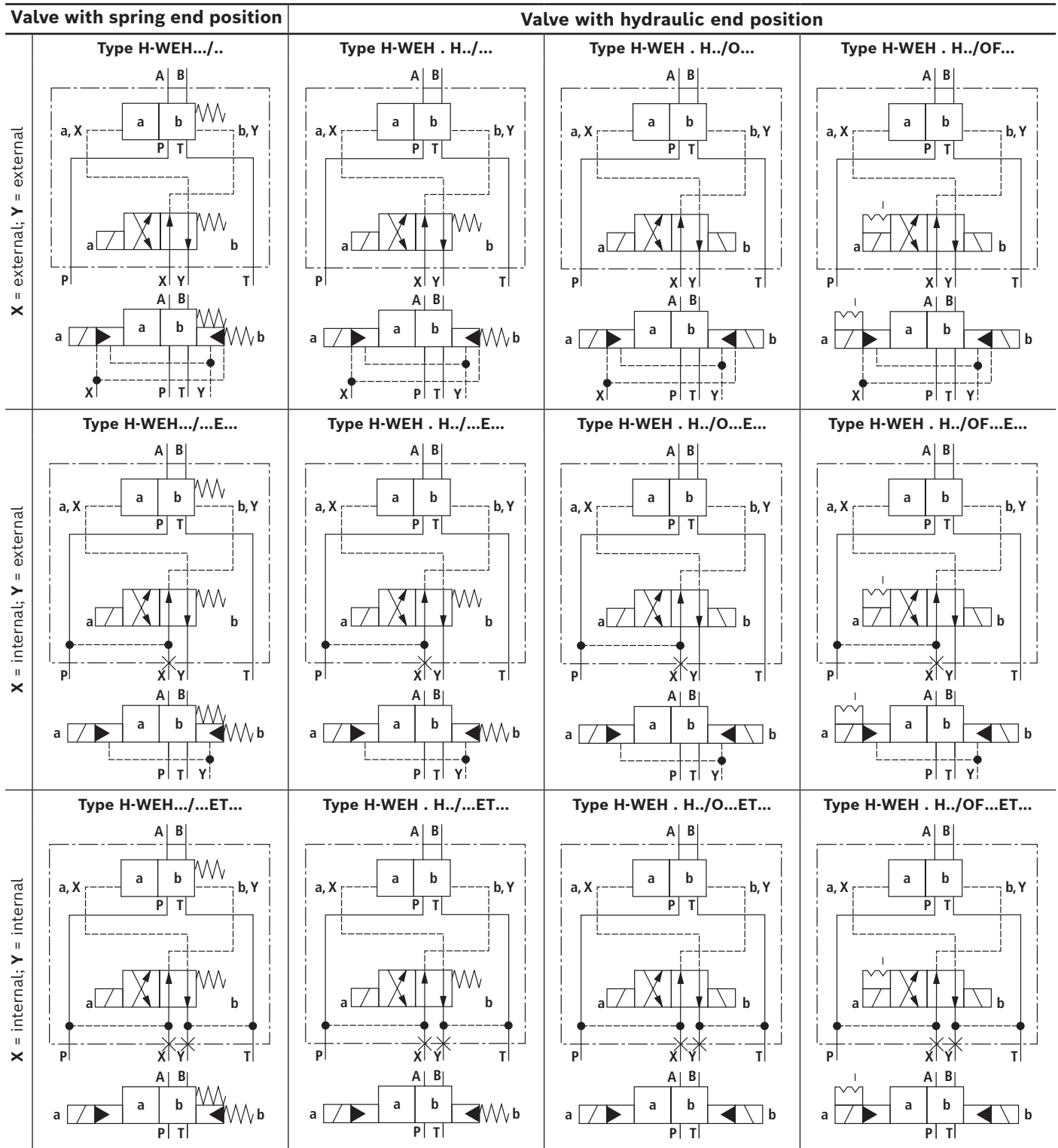

**Symbols:** Valve with 2 spool positions

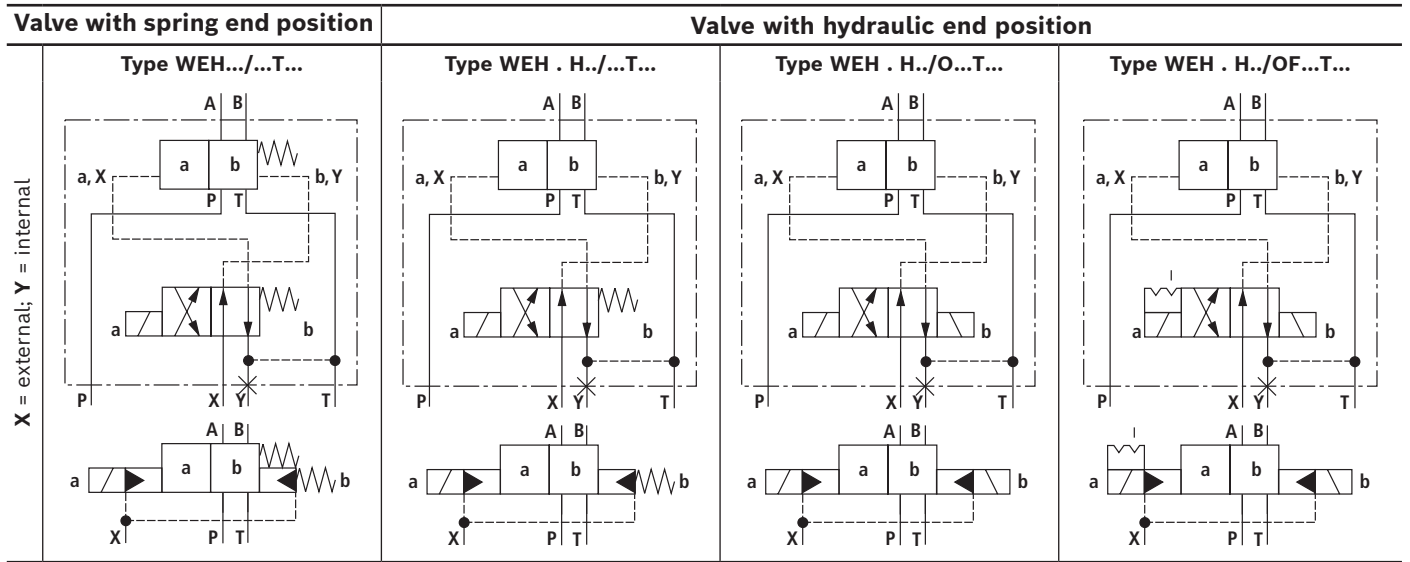

**Symbols:** Valves with 3 spool positions

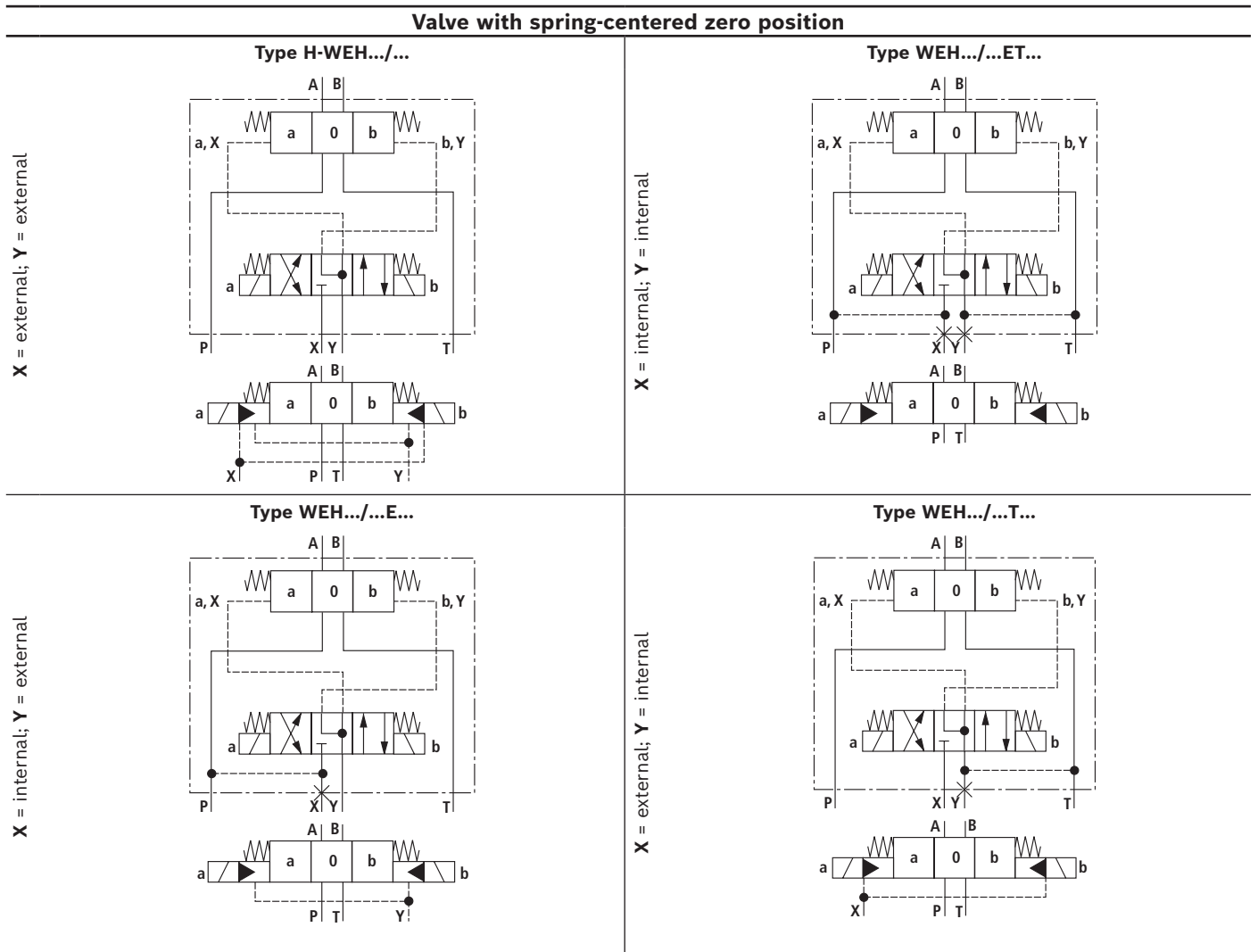

## Function, section

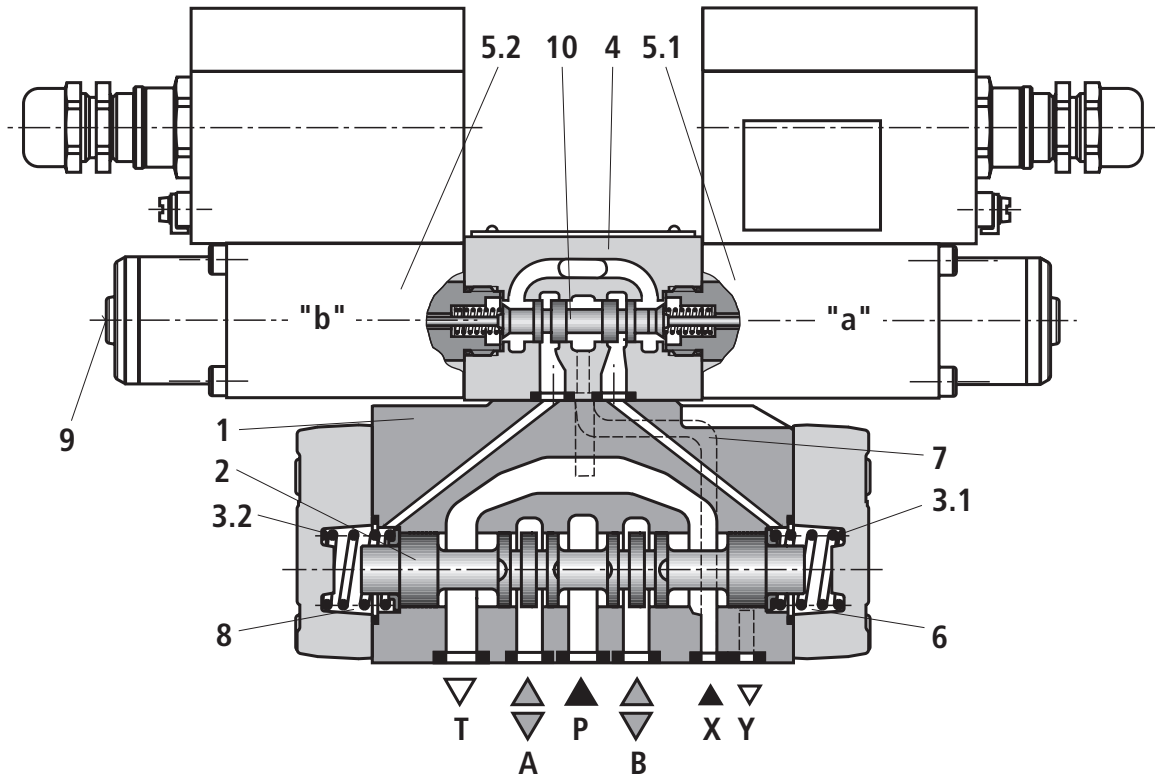

### Type H-4WEH 16...XD...

The valve type H-4WEH is a directional spool valve with electro-hydraulic actuation. It controls the start, stop and direction of a flow.

The directional valve basically consists of the main valve with housing (1), the main control spool (2), one or two return springs (3.1) and (3.2), as well as the pilot control valve (4) with one or two solenoids "a" (5.1) and/or "b" (5.2).

**For unobjectionable functioning, the hydraulic system has to be bled properly.**

The main control spool (2) in the main valve is held in the zero or initial position by the springs or by means of pressurization. In the initial position, the two spring chambers (6) and (8) are connected with the tank in a depressurized form via the pilot control valve (4). The pilot control valve is supplied with pilot oil via the control line (7). Supply can be effected internally or externally (externally via port X).

Upon actuation of the pilot control valve, e.g. solenoid "a", the pilot control spool (10) is moved to the left and thus, the spring chamber (8) is pressurized with pilot pressure. The spring chamber (6) remains depressurized.

The pilot pressure acts on the left side of the main control spool (2) and moves it against the spring (3.1). This connects ports P with B and A with T in the main valve. When the solenoid is switched off, the pilot control spool returns into the initial position (except for impulse spool). The spring chamber (8) is unloaded to the tank.

The pilot oil from the spring chamber is displaced into channel Y via the pilot control valve.

The pilot oil supply and return can be effected internally or externally.

The manual override (9) allows control spool (10) to be moved without solenoid energization.

#### Notice:

The main control spool (2) is held in central position by the return springs (3.1) and (3.2) in spring chambers (6) and (8) without pilot pressure, even if the valve is positioned for example vertically.

**Due to the design principle, internal leakage is inherent to the valves, which may increase over the life cycle.**



## Pilot oil supply

### Type H-WEH...

The pilot oil supply is effected **externally** via the X channel from a separate pressure supply.

The pilot oil return is effected **externally** via the Y channel into the tank.

### Type H-WEH...E...

The pilot oil supply is effected **internally** from the P channel of the main valve.

The pilot oil return is effected **externally** via the Y channel into the tank. In the subplate, port X is closed.

### Type H-WEH...ET...

The pilot oil supply is effected **internally** from the P channel of the main valve.

The pilot oil return is effected **internally** via the T channel into the tank. In the subplate, ports X and Y are closed.

### Type H-WEH...T...

The pilot oil supply is effected **externally** via the X channel from a separate pressure supply.

The pilot oil return is effected **internally** via the T channel into the tank. In the subplate, port Y is closed.

### Throttle insert

Use of the throttle insert (2) is necessary if the pilot oil supply in the P channel of the pilot control valve is to be limited (see below).

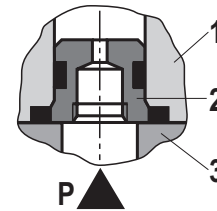

- 1 Pilot control valve
- 2 Throttle insert
- 3 Main valve

**Technical data**

(for applications outside these values, please consult us!)

<b>General</b>						
Sizes	NG	10	16	25	32	
Weight, approx.	▶ Valve with one solenoid	kg	11	13.5	22	39
	▶ Valve with two solenoids, spring-centered	kg	14	16.5	25	42
	▶ Version "S" and "S2"	kg	0.8	0.8	0.8	0.8
	▶ Version "D3"	kg	0.4	0.4	0.4	0.4
Installation position		any <sup>1)</sup>				
Ambient temperature range	°C	-20 ... +80				
Storage temperature range	°C	+5 ... +40				
Maximum storage time	Years	1				
Maximum admissible acceleration $a_{max}$	g	10				
Surface protection		galvanized				
MTTF <sub>D</sub> value according to EN ISO 13849	Years	100				
Maximum surface temperature	°C	See information on explosion protection on page 12				

<b>Hydraulic</b>							
Sizes	NG	10	16	25	32		
Maximum operating pressure	▶ Ports P, A, B	bar	350				
	▶ Port T	- Pilot oil return Y external	bar	250			
		- Pilot oil return Y internal	bar	210			
	▶ Port Y	- Pilot oil return external	bar	210			
		Maximum flow of the main valve	l/min	160	300	700	1100
Maximum pilot pressure	▶ Port X	- Without version "D3"	bar	250			
		- With version "D3"	bar	350			
	Minimum pilot pressure						
▶ Pilot oil supply X external or internal (control spool D, K, E, J, L, M, Q, R, U, W)	- 3 spool position valve, spring-centered	bar	12	14	13	8.5	
	- 2 spool position valve, spring end position	bar	10	14	13	10	
	- 2 spool position valve, hydraulic end position	bar	7	14	8	5	
	▶ Pilot oil supply X internal (control spool C, F, H, P, T, V, Z, S <sup>2)</sup> )	bar	7.5 <sup>3)</sup>	4.5 <sup>4)</sup>	4.5 <sup>4)</sup>	4.5 <sup>4)</sup>	
Pilot volume for switching process	▶ 3 spool position valve, spring-centered	cm <sup>3</sup>	2.04	5.72	14.2	29.4	
	▶ 2 spool position valve	cm <sup>3</sup>	4.08	11.45	28.4	58.8	
	Pilot volume for shortest switching time, approx.	l/min	35	35	35	45	
Hydraulic fluid		See table page 11					
Hydraulic fluid temperature range	°C	-20 ... +80 (NBR seals) -15 ... +80 (FKM seals)					
Viscosity range	mm <sup>2</sup> /s	2.8 ... 500					
Maximum admissible degree of contamination of the hydraulic fluid, cleanliness class according to ISO 4406 (c)		Class 20/18/15 <sup>5)</sup>					

## Technical data

(for applications outside these values, please consult us!)

Hydraulic fluid		Classification	Suitable sealing materials	Standards	Data sheet
Mineral oils		HL, HLP, HLPD	NBR, FKM	DIN 51524	90220
Bio-degradable	▶ Insoluble in water	HETG	FKM	ISO 15380	90221
		HEES	FKM		
	▶ Soluble in water	HEPG	FKM	ISO 15380	
Flame-resistant	▶ Containing water	HFC (Fuchs: Hydrotherm 46M, Renosafe 500; Petrofer: Ultra Safe 620; Houghton: Safe 620; Union: Carbide HP5046)	NBR	ISO 12922	90223



### Important information on hydraulic fluids:

- ▶ For further information and data on the use of other hydraulic fluids, please refer to the data sheets above or contact us.
- ▶ There may be limitations regarding the technical valve data (temperature, pressure range, life cycle, maintenance intervals, etc.).
- ▶ The ignition temperature of the hydraulic fluid used must be 50 K higher than the maximum surface temperature.
- ▶ **Bio-degradable and flame-resistant – containing water:**  
If components with galvanic zinc coating (e.g. version "J3" or "J5") or parts containing zinc are used, small amounts of dissolved zinc may get into the hydraulic system and cause accelerated aging of the hydraulic fluid. Zinc soap may form as a chemical reaction product, which may clog filters, nozzles and solenoid valves – particularly in connection with local heat input.

### ▶ Flame-resistant – containing water:

- Due to increased cavitation tendency with HFC hydraulic fluids, the life cycle of the component may be reduced by up to 30% as compared to the use with mineral oil HLP. In order to reduce the cavitation effect, it is recommended – if possible specific to the installation – to back up the return flow pressure in ports T to approx. 20% of the pressure differential at the component.
- Dependent on the hydraulic fluid used, the maximum ambient and hydraulic fluid temperature must not exceed 50 °C. In order to reduce the heat input into the component, a maximum duty cycle of 50% in continuous operation has to be set for on/off valves (measuring period 300 s).

- 1) Suspended installation leads to a higher sensitivity to contamination. Horizontal positioning is recommended. Valves with hydraulic control spool return "H" and symbol C, D, K, Z, Y require horizontal.
- 2) Symbol S only for NG16
- 3) For symbols C, F, G, H, P, T, V, Z, an internal pilot oil supply without preload valve is only possible if the flow from P → T in the central position (for 3 spool position valve) or while crossing the central position (for 2 spool position valve) is so large that the pressure differential of P → T reaches a value of at least 7.5 bar. At a pressure differential below 7.5 bar, a check valve with a cracking pressure of 7.5 bar must be installed in the return line to the tank. Pilot oil return Y must be realized externally.

- 4) For symbols C, F, G, H, P, T, V, Z, S <sup>1)</sup> – by means of a preload valve or a correspondingly high flow
- 5) The cleanliness classes specified for the components must be adhered to in hydraulic systems. Effective filtration prevents faults and simultaneously increases the life cycle of the components.  
Available filters can be found at [www.boschrexroth.com/filter](http://www.boschrexroth.com/filter).

**Technical data**

(for applications outside these values, please consult us!)

Electric	
Voltage type	Direct voltage
Available voltages	V 24
Voltage tolerance (nominal voltage)	% $\pm 10$
Admissible residual ripple	% < 5
Duty cycle / operating mode according to VDE 0580	S1 (continuous operation)
Switching time according to ISO 6403	See page 13
Maximum switching frequency	1/h 15000
Switch-off voltage peak Solenoid	V 500 (suitable damping by user required)
Nominal power at ambient temperature 20°C	W 13
Maximum power with 1.1 x nominal voltage and ambient temperature 20 °C	W 15.8
Protection class according to EN 60529	IP65 (with correctly installed electrical connection)

Information on explosion protection		
Area of application	I M2	II 2G
Type of protection of valve according to EN 80079-36 / EN 80079-38 <sup>6)</sup>	Ex h I Mb X	Ex h IIC T4 Gb X
Type of protection valve solenoid according to EN 60079-1	Ex db I Mb	Ex db IIC T4 Gb
Maximum surface temperature <sup>7)</sup>	°C 105	
Temperature class	-	T4
Type examination certificate solenoid	BVS 03 ATEX E 300 X	
"IECEx Certificate of Conformity" solenoid	IECEx BVS 11.0091X	

<sup>6)</sup> Ex h: structural safety c according to EN 80079-37.

<sup>7)</sup> Surface temperature > 50 °C, provide contact protection.

**Special application conditions for safe application:**

- ▶ Connection lines must be passed in a strain-relieved way. The first mounting point must be within 150 mm of the cable and line entry.
- ▶ In order to avoid dangers caused by static charge, the base and/or subplate on which the valve is to be fitted must be electrically conductive and included in the equipotential bonding.
- ▶ The valve solenoid must not be installed close to charge generating processes.
- ▶ Contact of the connection cable with the casing surface is to be prevented.

## Switching times

Pilot pressure		bar	70		250	Spring
			ON		ON	OFF
NG10	▶ Without throttle insert	ms	50 ... 70	50 ... 70	50 ... 70	30 ... 40
	▶ With throttle insert	ms	70 ... 100	60 ... 80	60 ... 80	30 ... 40
NG16	▶ Without throttle insert	ms	60 ... 90	50 ... 70	50 ... 70	60 ... 90
	▶ With throttle insert	ms	120 ... 140	90 ... 110	90 ... 110	60 ... 90
NG25	▶ Without throttle insert	ms	80 ... 110	60 ... 80	60 ... 80	110 ... 140
	▶ With throttle insert	ms	210 ... 260	130 ... 160	130 ... 160	110 ... 140
NG32	▶ Without throttle insert	ms	90 ... 140	80 ... 110	80 ... 110	150 ... 170
	▶ With throttle insert	ms	430 ... 570	240 ... 360	240 ... 360	150 ... 170

### Notices:

- ▶ Switching time (= Contacting at the pilot control valve until start of opening of the control edge in the main valve and change in the control spool stroke by 95%)
- ▶ The switching times are measured according to ISO 6403 with HLP46,  $\vartheta_{oil} = 40 \text{ °C} \pm 5 \text{ °C}$ .  
With different oil temperatures, variations may occur.
- ▶ The switching times increase by approx. 30 ms if the pressure reducing valve "D3" is used.
- ▶ The switching times have been determined under ideal conditions and may differ in the system, depending on the application conditions.

### Free flow cross-sections in zero position with symbols Q, V and W

Symbol <b>Q</b>	A – T, B – T	mm <sup>2</sup>	13	32	78	83	78
Symbol <b>V</b>	A – T, B – T	mm <sup>2</sup>	13	32	73	83	73
	P – A, P – B	mm <sup>2</sup>	13	32	84	83	84
Symbol <b>W</b>	A – T, B – T	mm <sup>2</sup>	2.4	6	10	14	20

**Characteristic curves: NG10**

(measured with HLP46,  $\vartheta_{oil} = 40 \pm 5 \text{ }^\circ\text{C}$ )

$\Delta p$ - $q_v$  characteristic curves

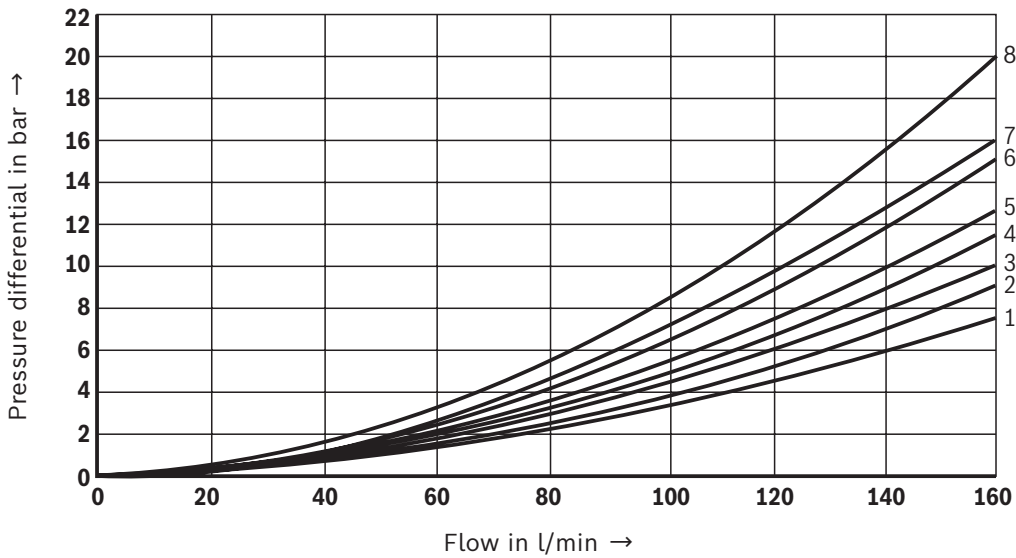

Symbol	Spool position				Zero position		
	P - A	P - B	A - T <sup>1)</sup>	B - T <sup>1)</sup>	A - T	B - T	P - T
E, Y, D, Q, V, W, Z	1	1	3	5			
F	1	3	1	4	3	-	6
G, T	4	2	4	7	-	-	8
H, C	3	3	1	7	1	5	5
J, K	1	2	1	6			
L	2	2	1	4	2	-	-
M	3	3	2	5			
P	3	1	2	7	-	5	7
R	1	2	3	-			
U	2	2	3	6	-	6	-

<sup>1)</sup> The pressure differential refers to the use of port T. If port T1 is to be used additionally, the pressure differential may be reduced. If only port T1 is used, the proportions of A - T and B - T may be reversed.

**Performance limits: NG10**

(measured with HLP46,  $\vartheta_{oil} = 40 \pm 5 \text{ }^\circ\text{C}$ )

**2 spool position valves –  $q_{v \max}$  in l/min**

Symbol	Operating pressure $p_{\max}$ in bar				
	70	140	210	280	350
<b>X external – spring end position in the main valve<sup>1)</sup></b> (with $p_{St \min} = 12 \text{ bar}$ )					
C, D, K, Y, Z	160	160	160	160	160
<b>X external – hydraulic end position in the main valve</b>					
HC, HD, HK, HZ, HY	160	160	160	160	160

**3 spool position valves –  $q_{v \max}$  in l/min**

Symbol	Operating pressure $p_{\max}$ in bar				
	70	140	210	280	350
<b>X external – spring-centered</b>					
E, J, L, M, Q, U, V, W, R	160	160	160	160	160
F, P	160	120	100	90	90
G, T	160	160	160	130	120
H	160	160	120	110	100

<sup>1)</sup> In case of pilot pressure loss, the function of the return spring can no longer be ensured at the specified flow values.

Important notices see page 20.

**Characteristic curves: NG16**  
(measured with HLP46,  $\vartheta_{oil} = 40 \pm 5 \text{ }^\circ\text{C}$ )

$\Delta p$ - $q_V$  characteristic curves

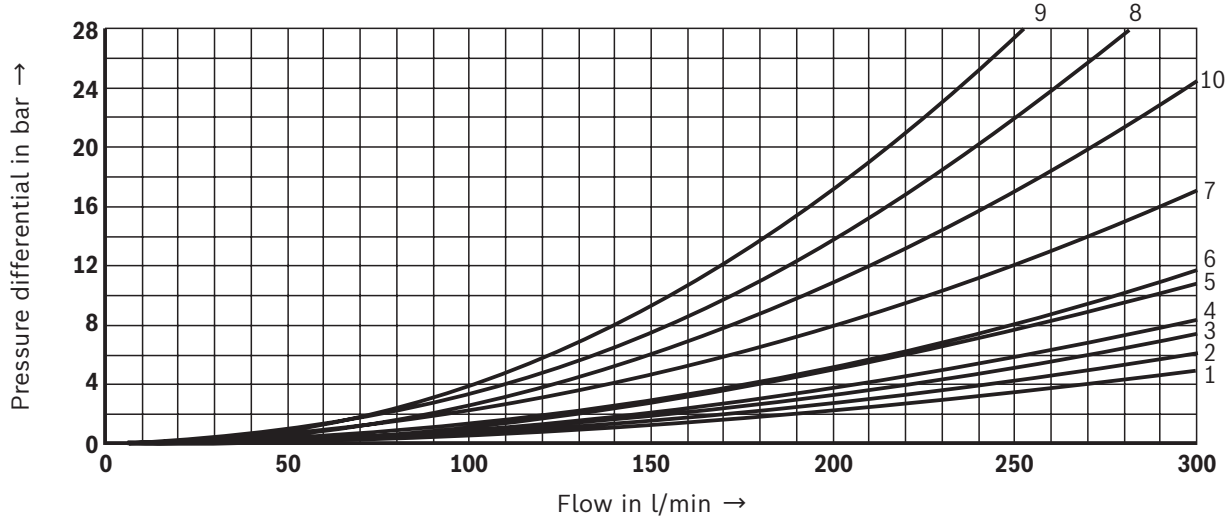

Symbol	Spool position				Zero position		
	P - A	P - B	A - T	B - T	P - T	A - T	B - T
D, E, Y	1	1	3	3			
F	1	2	5	5	4	3	-
G	4	1	5	5	7	-	-
C, H	1	1	5	6	2	4	4
K, J	2	2	6	6	-	3	-
L	2	2	5	4	-	3	-
M	1	1	3	4			
P	2	1	3	6	5	-	-

Symbol	Spool position				Zero position		
	P - A	P - B	A - T	B - T	P - T	A - T	B - T
Q	1	1	6	6			
R	2	4	7	-			
S	3	3	3	-	9	-	-
T	4	1	5	5	7	-	-
U	2	2	3	4			6
V, Z	1	1	6	6	10	8	8
W	1	1	3	4			

**Performance limits: NG16**  
(measured with HLP46,  $\vartheta_{oil} = 40 \pm 5 \text{ }^\circ\text{C}$ )

**2 spool position valves** –  $q_{V \max}$  in l/min

Symbol	Operating pressure $p_{\max}$ in bar				
	70	140	210	280	350
<b>X external – spring end position in the main valve</b> (with $p_{St \min} = 12 \text{ bar}$ )					
C, D, K, Y, Z	300	300	300	300	300
<b>X external – spring end position in the main valve <sup>1)</sup></b>					
C	300	300	300	300	300
D, Y	300	270	260	250	230
K	300	250	240	230	210
Z	300	260	190	180	160
<b>X external – hydraulic end position in the main valve</b>					
HC, HD, HK, HZ, HY	300	300	300	300	300

**3 spool position valves** –  $q_{V \max}$  in l/min

Symbol	Operating pressure $p_{\max}$ in bar				
	70	140	210	280	350
<b>X external – spring-centered</b>					
E, H, J, L, M, Q, U, W, R	300	300	300	300	300
F, P	300	250	180	170	150
G, T	300	300	240	210	190
S	300	300	300	250	220
V	300	250	210	200	180

<sup>1)</sup> If the specified flow values are exceeded, the function of the return spring is no longer guaranteed if the pilot pressure fails.

**Important notices see page 20.**

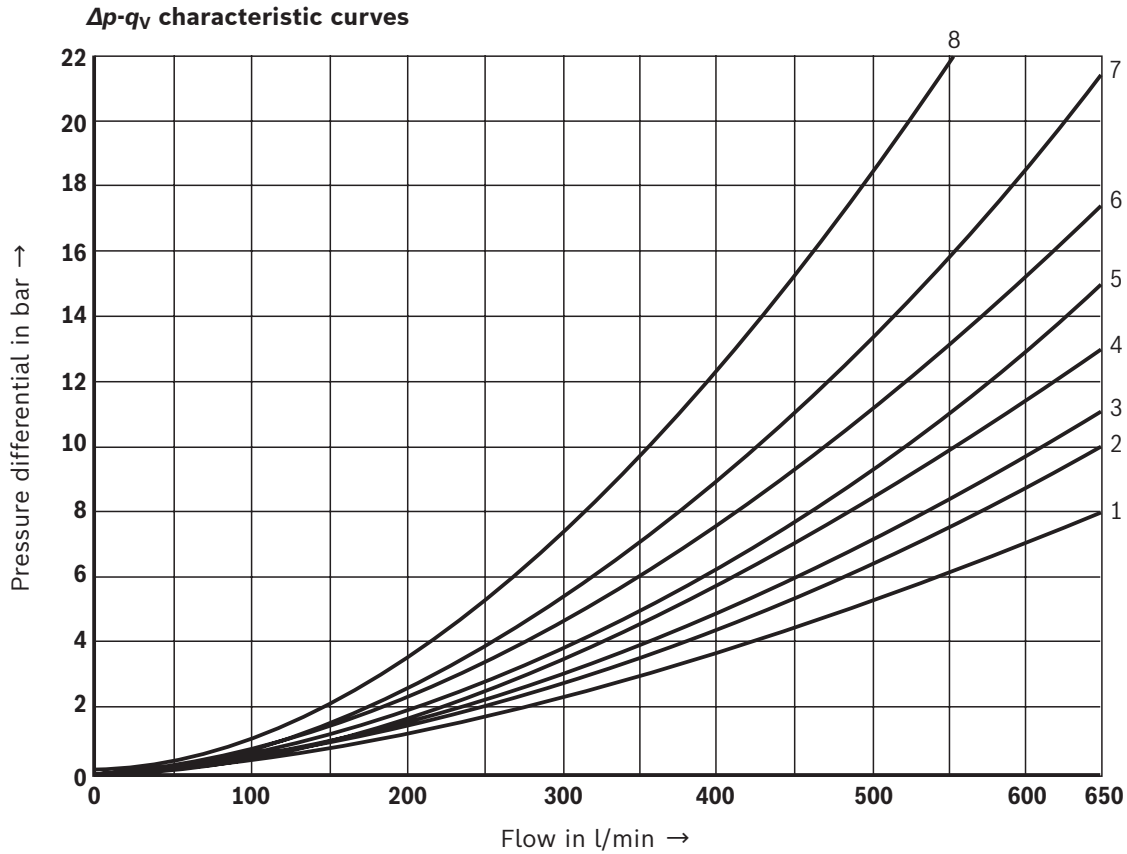
**Characteristic curves: NG25**(measured with HLP46,  $\vartheta_{\text{oil}} = 40 \pm 5 \text{ }^\circ\text{C}$ )

Symbol	Spool position				Zero position		
	P - A	P - B	A - T <sup>1)</sup>	B - T <sup>1)</sup>	A - T	B - T	P - T
E, Y, D	1	1	3	4			
F	1	1	2	4	2	-	5
G, T	1	1	2	5	-	-	7
H	1	1	2	5	2	2	4
C	1	1	2	5			
J	1	1	2	5	6	5	-
K	1	1	2	5			
L	1	1	2	4	5	-	-
M	1	1	3	4			
P	1	1	3	5	-	3	5
Q	1	1	2	3			
R	1	1	3	-			
U	1	1	2	5	-	5	-
V	1	1	2	5	8	7	-
Z	1	1	2	5			
W	1	1	3	4			

8 Symbol R, spool position B - A



**Performance limits: NG25**  
(measured with HLP46,  $\vartheta_{oil} = 40 \pm 5 \text{ }^\circ\text{C}$ )

**2 spool position valves –  $q_{V \max}$  in l/min**

Symbol	Operating pressure $p_{\max}$ in bar				
	70	140	210	280	350
<b>X external – spring end position in the main valve</b> (with $p_{St \min} = 13 \text{ bar}$ )					
C, D, K, Y, Z	700	700	700	700	650
<b>X external – spring end position in the main valve <sup>1)</sup></b>					
C	700	700	700	700	650
D, Y	700	650	400	350	300
K	700	650	420	370	320
Z	700	700	650	480	400
<b>X external – hydraulic end position in the main valve</b>					
HC, HD, HK, HZ, HY	700	700	700	700	700
HC./O..., HD./O..., HK./O..., HZ./O...	700	700	700	700	700
HC./OF..., HD./OF..., HK./OF..., HZ./OF...	700	700	700	700	700

<sup>1)</sup> If the specified flow values are exceeded, the function of the return spring is no longer guaranteed if the pilot pressure fails.

**3 spool position valves –  $q_{V \max}$  in l/min**

Symbol	Operating pressure $p_{\max}$ in bar				
	70	140	210	280	350
<b>X external – spring-centered</b>					
E, L, M, Q, U, W	700	700	700	700	650
G, T	400	400	400	400	400
F	650	550	430	330	300
H	700	650	550	400	360
J	700	700	650	600	520
P	650	550	430	330	300
V	650	550	400	350	310
R	700	700	700	650	580

 **Important notices see page 20.**

**Characteristic curves: NG32**  
 (measured with HLP46,  $\vartheta_{oil} = 40 \pm 5 \text{ }^\circ\text{C}$ )

$\Delta p$ - $q_v$  characteristic curves

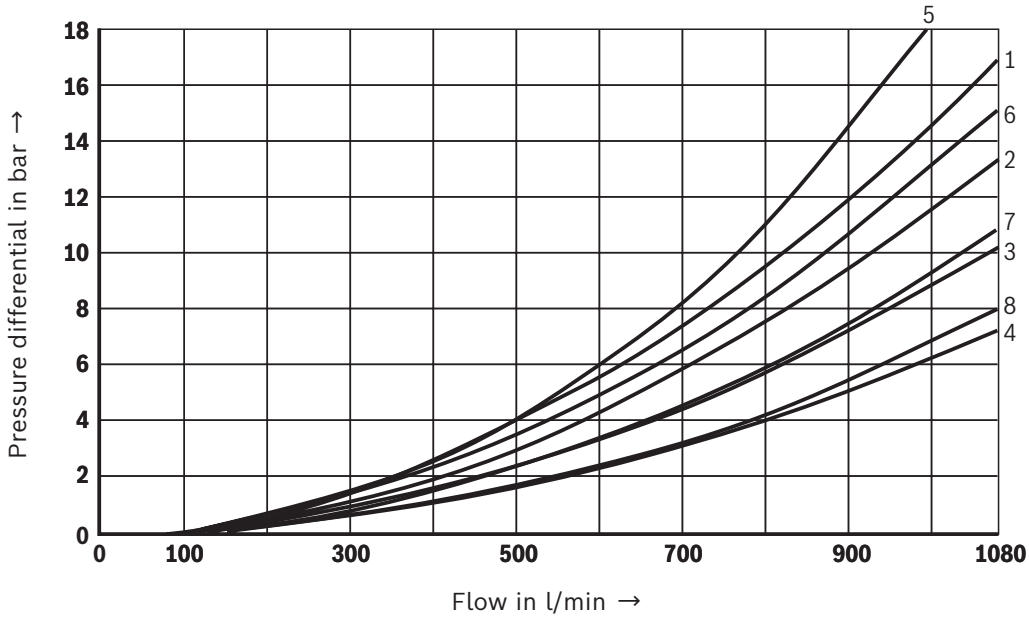

Symbol	Spool position					
	P - A	P - B	A - T	B - T	B - A	P - T
E	4	4	3	2	-	-
R	4	4	3	-	1	-
W	4	4	3	2	-	-
G	7	8	7	5	-	6
T	7	8	7	5	-	6

**Performance limits: NG32**  
(measured with HLP46,  $\vartheta_{oil} = 40 \pm 5 \text{ }^\circ\text{C}$ )

**2 spool position valves –  $q_{V \max}$  in l/min**

Symbol	Operating pressure $p_{\max}$ in bar				
	70	140	210	280	350
<b>X external – spring end position in the main valve</b> (with $p_{St \min} = 10 \text{ bar}$ )					
C, D, K, Y, Z	1100	1040	860	750	680
<b>X external – spring end position in the main valve <sup>1)</sup></b>					
C	1100	1040	860	800	700
D, Y	1100	1040	540	480	420
K	1100	1040	860	500	450
Z	1100	1040	860	700	650
<b>X external – hydraulic end position in the main valve</b>					
HC, HD, HK, HZ, HY	1100	1040	860	750	680

<sup>1)</sup> If the specified flow values are exceeded, the function of the return spring is no longer guaranteed if the pilot pressure fails.

**3 spool position valves –  $q_{V \max}$  in l/min**

Symbol	Operating pressure $p_{\max}$ in bar				
	70	140	210	280	350
<b>X external – spring-centered</b>					
E, J, L, M, Q, R, U, W	1100	1040	860	750	680
G, T, H, F, P	900	900	800	650	450
V	1100	1000	680	500	450

 **Important notices see page 20.**

**Performance limits:** important notices

 **Notice** (applies to all sizes):  
 The specified switching power limits are valid for use with two directions of flow (e.g. from P to A and simultaneous return flow from B to T at a ratio of 1:1). Due to the flow forces acting within the valves, the admissible switching power limit may be considerably lower with only one direction of flow (e. g. from P to A while port B is blocked, with flow in the same or different directions)! In such cases, please consult us.  
**The switching power limit was established while the solenoids were at operating temperature, at 10% undervoltage and without tank preloading.**

<b>NG16</b>	<ul style="list-style-type: none"> <li>▶ With pilot oil supply <b>X internal</b>, a preload valve has to be used for flows &lt; 160 l/min due to the negative overlap of symbols C, V and HC, HZ.</li> <li>▶ With pilot oil supply <b>X internal</b>, sufficient flow has to be ensured due to the negative overlap of symbols F, G, H, P, S and T (for the determination of the required flow, see "Preload valve" characteristic curves (page 26). If the required flow is not reached, a preload valve has to be used (see page 10).</li> </ul>
<b>NG25</b>	<ul style="list-style-type: none"> <li>▶ With pilot oil supply <b>X internal</b>, a preload valve has to be used for flows &lt; 180 l/min due to the negative overlap of the symbols Z, HZ and V.</li> <li>▶ With pilot oil supply <b>X internal</b>, sufficient flow has to be ensured due to the negative overlap of symbols C, HC, F, G, H, P, and T (for the determination of the required flow, see "Preload valve" characteristic curves (page 26). If the required flow is not reached, a preload valve has to be used (see page 10).</li> </ul>
<b>NG32</b>	<ul style="list-style-type: none"> <li>▶ With pilot oil supply <b>X internal</b>, a preload valve has to be used for flows &lt; 180 l/min due to the negative overlap of the symbols Z, HZ and V.</li> <li>▶ With pilot oil supply <b>X internal</b>, sufficient flow has to be ensured due to the negative overlap of symbols C, HC, F, G, H, P, and T (for the determination of the required flow, see "Preload valve" characteristic curves (page 26). If the required flow is not reached, a preload valve has to be used (see page 10).</li> </ul>

**Dimensions:** NG10  
(dimensions in mm)

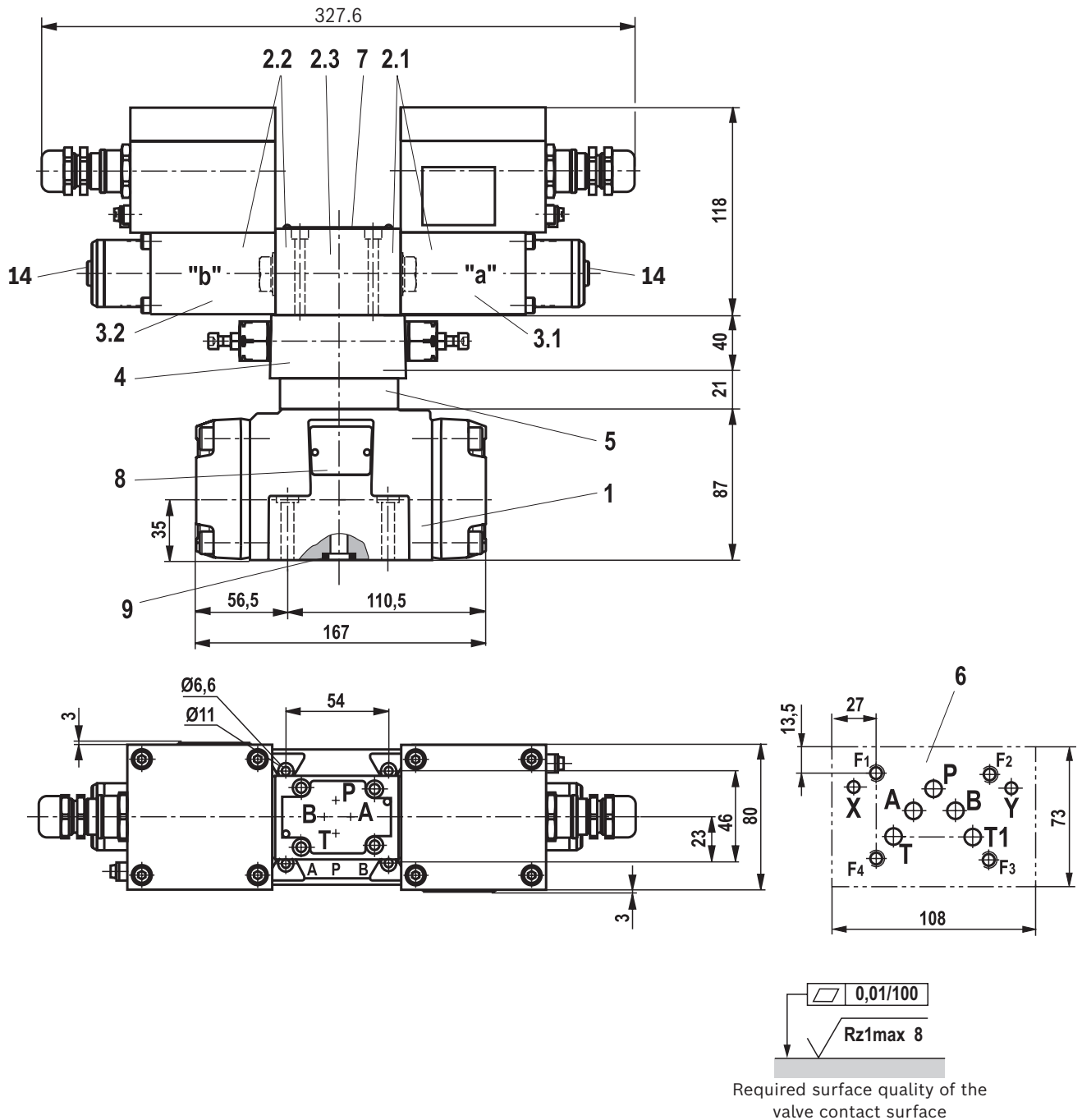

**Notice:**

The dimensions are nominal dimensions which are subject to tolerances.

For item explanations, valve mounting screws and subplates, see page 25.

**Dimensions:** NG16  
(dimensions in mm)

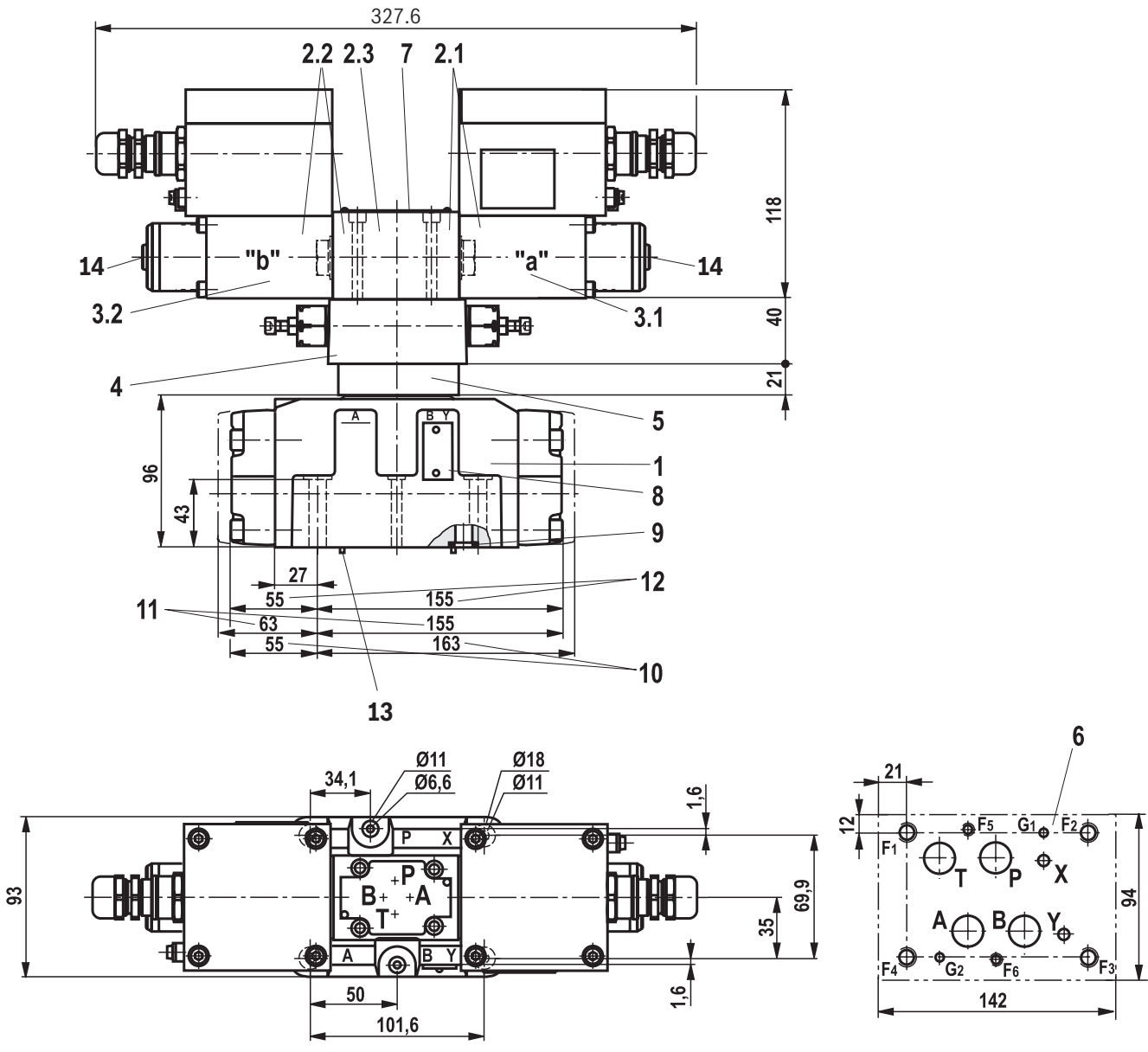

Required surface quality of the valve contact surface

**Notice:**  
The dimensions are nominal dimensions which are subject to tolerances.

For item explanations, valve mounting screws and subplates, see page 25.

**Dimensions:** NG25  
(dimensions in mm)

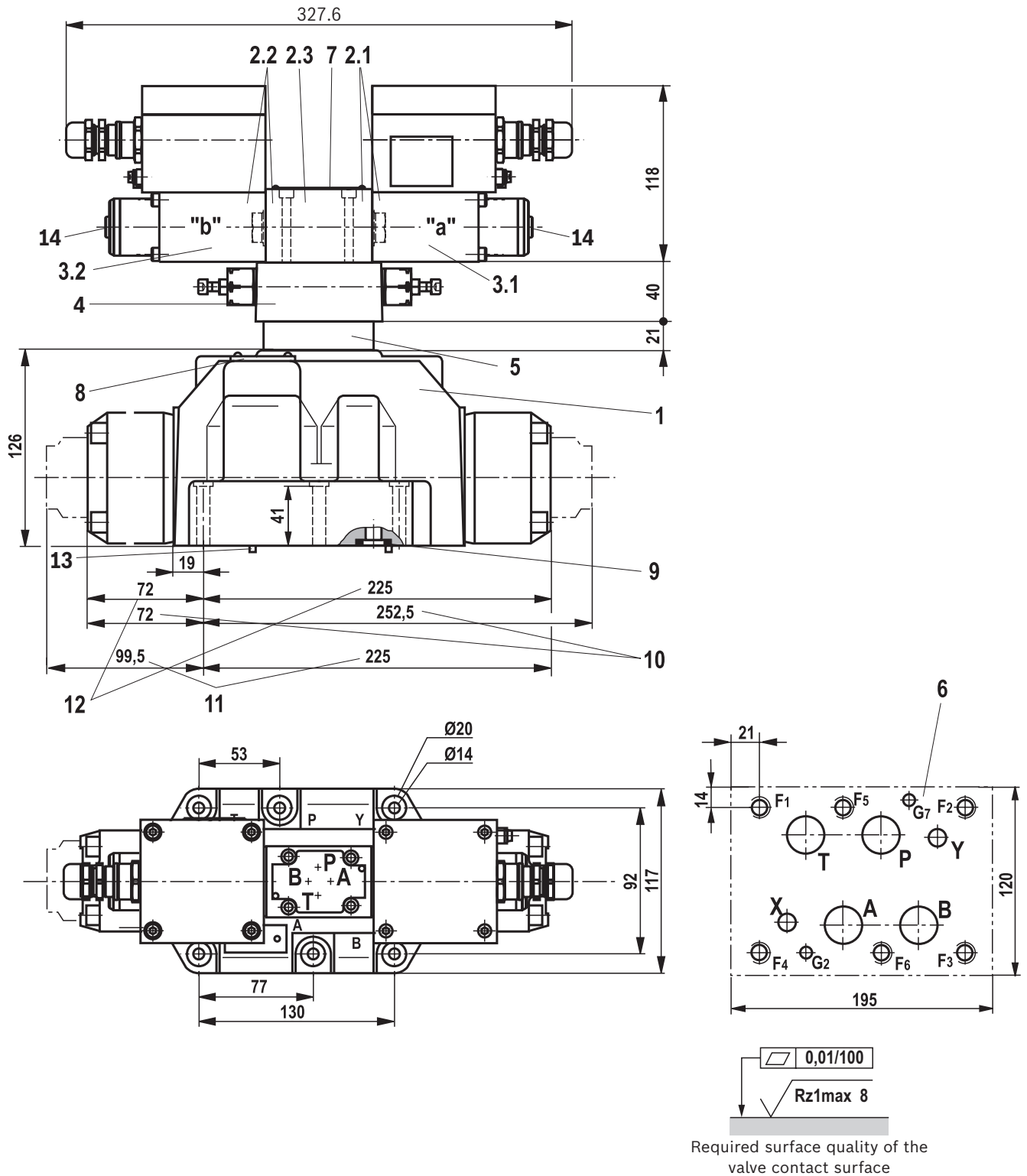

**Notice:**

The dimensions are nominal dimensions which are subject to tolerances.

For item explanations, valve mounting screws and subplates, see page 25.

**Dimensions:** NG32  
(dimensions in mm)

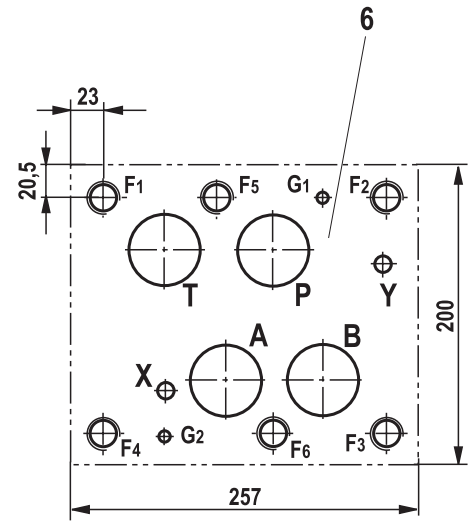
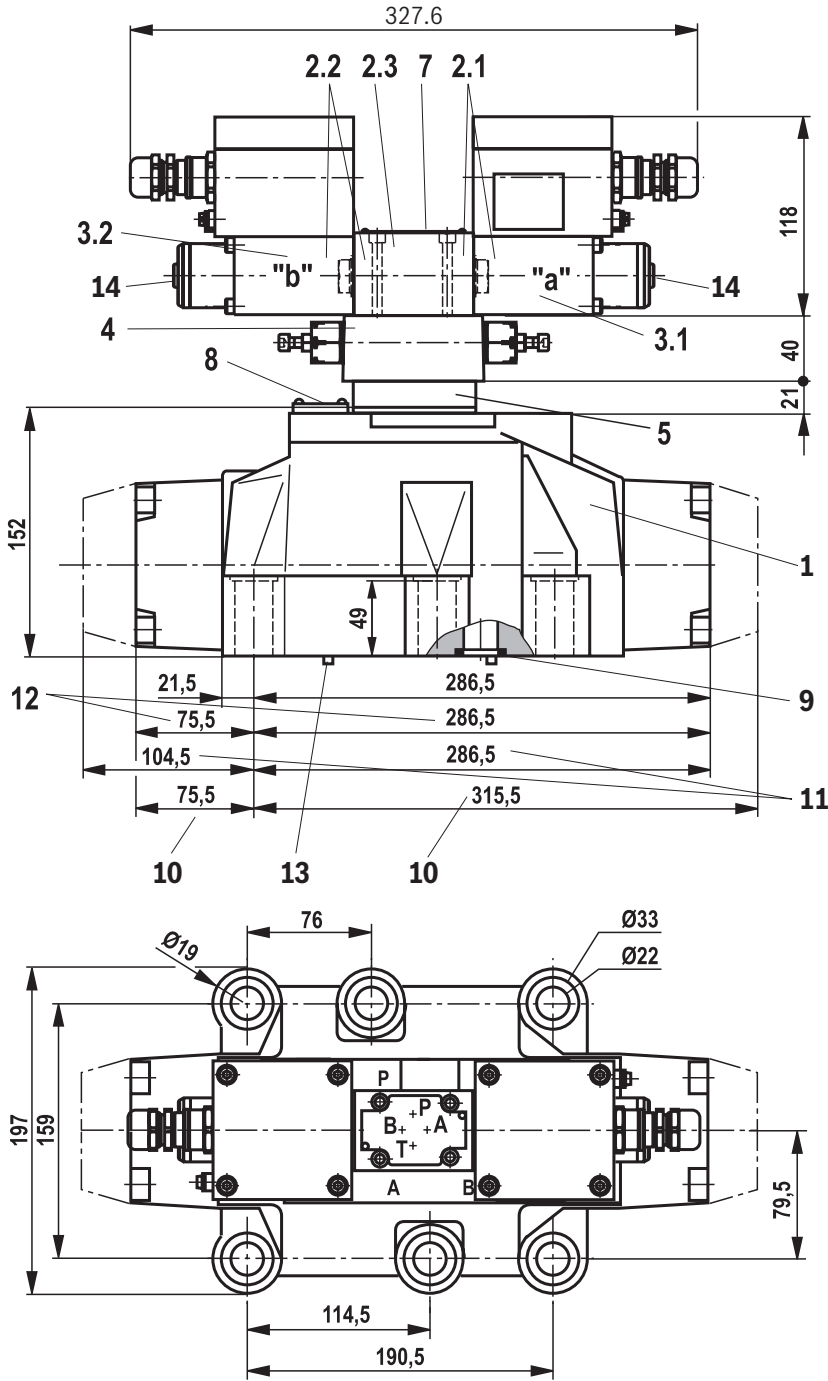

**Notice:**  
The dimensions are nominal dimensions which are subject to tolerances.

0,01/100  
Rz1max 8  
Required surface quality of the valve contact surface

For item explanations, valve mounting screws and subplates, see page 25.



## Dimensions

- 1 Main valve
- 2.1 ▶ Pilot control valve type 4WE 6 D... (1 solenoid)  
for main valves with Symbols C, D, K, Z  
Symbols HC, HD, HK, HZ
- ▶ Pilot control valve type 4WE 6 JA... (1 solenoid "a")  
for main valves with symbols EA, FA, etc.,  
spring return
- 2.2 ▶ Pilot control valve type 4WE 6 Y... (1 solenoid)  
for main valves with Symbol Y:  
Symbol HY
- ▶ Pilot control valve type 4WE 6 JB... (1 solenoid "b")  
for main valves with symbol EB, FB, etc.,  
spring return
- 2.3 ▶ Pilot control valve type 4WE 6 J... (2 solenoids)  
for main valves with 3 spool positions, spring-centered
- 3.1 Solenoid "a"
- 3.2 Solenoid "b"
- 4 Switching time adjustment (SW6), optional
- 5 Pressure reducing valve, optional
- 6 Machined valve contact surface; porting pattern  
according to
  - ▶ NG10: ISO 4401-05-05-0-05
  - ▶ NG16: ISO 4401-07-07-0-05
  - ▶ NG25: ISO 4401-08-08-0-05
  - ▶ NG32: ISO 4401-10-09-0-05
- 7 Name plate pilot control valve
- 8 Name plate of complete valve
- 9 Seal rings
- 10 2 spool position valves with spring end position in the main  
valve (symbols C, D, K, Z)
- 11 2 spool position valves with spring end position in the main  
valve (symbol Y)
- 12 3 spool position valves, spring-centered  
2 spool position valves with hydraulic end position in the  
main valve
- 13 Locking pin
- 14 Manual override "N"

**Subplates** (separate order) with porting pattern according to ISO 4401 see data sheet 45100.



### Notice:

Subplates are no components in the sense of Directive 2014/34/EU and can be used after the manufacturer of the overall system has conducted an assessment of the risk of ignition. The "G...J3" versions are free from aluminum and/or magnesium and galvanized.

### Valve mounting screws (separate order)

Size	Quantity	Hexagon socket head cap screws	Material number
10	4	<b>ISO 4762 - M6 x 45 - 10.9</b> Friction coefficient $\mu_{\text{total}} = 0.09 \dots 0.14$ ; tightening torque $M_A = 12.5 \text{ Nm} \pm 10\%$	<b>R913043777</b>
16	4	<b>ISO 4762 - M10 x 60 - 10.9</b> Friction coefficient $\mu_{\text{total}} = 0.09 \dots 0.14$ ; tightening torque $M_A = 58 \text{ Nm} \pm 10\%$	<b>R913014770</b>
	2	<b>ISO 4762 - M6 x 60 - 10.9</b> Friction coefficient $\mu_{\text{total}} = 0.09 \dots 0.14$ ; tightening torque $M_A = 12.5 \text{ Nm} \pm 10\%$	<b>R913043410</b>
25	6	<b>ISO 4762 - M12 x 60 - 10.9</b> Friction coefficient $\mu_{\text{total}} = 0.09 \dots 0.14$ ; tightening torque $M_A = 100 \text{ Nm} \pm 10\%$	<b>R913015613</b>
32	6	<b>ISO 4762 - M20 x 80 - 10.9</b> Friction coefficient $\mu_{\text{total}} = 0.09 \dots 0.14$ ; tightening torque $M_A = 340 \text{ Nm} \pm 10\%$	<b>R913008472</b>

### Switching time adjustment

The switching time of the main valve (1) is influenced by using a twin throttle check valve (2) (type Z2FS 6).

- 3 Supply control
- 4 Discharge control

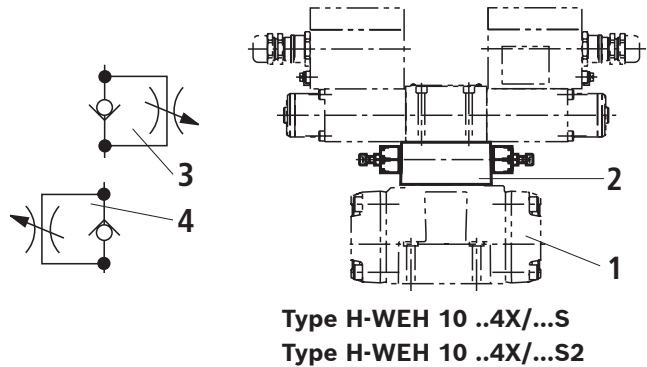

### Pressure reducing valve "D3"

With the design internal pilot oil supply ("ET"; "E") or external pilot oil supply and a pilot pressure of more than 250 bar, the valve must be ordered with a pressure reducing valve (5), type ZDR 6 PO, and a throttle insert "B10".

Ordering code: "B10..D3"

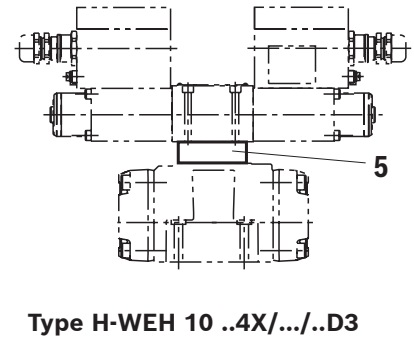

### Preload valve (not for NG10)

In case of valves with depressurized circulation and internal pilot oil supply, a preload valve is required in channel P of the main valve in order to build up the minimum pilot pressure.

The pressure differential of the preload valve is to be added to the pressure differential of the main valve (see characteristic curves) to result in one total value. The cracking pressure amounts to approx. 4.5 bar.

$\Delta p$ - $q_v$  characteristic curve (measured with HLP46,  $\vartheta_{oil} = 40 \pm 5 \text{ }^\circ\text{C}$ )

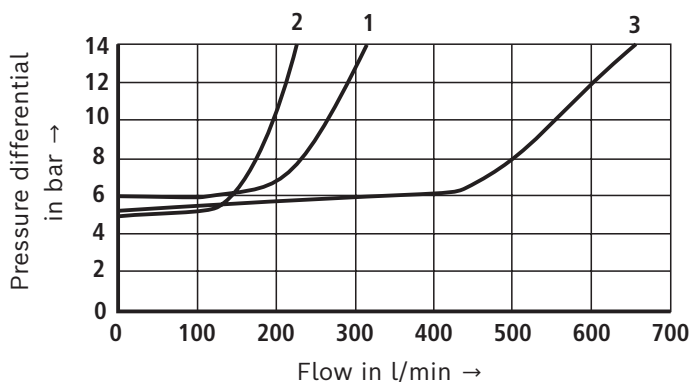

- 1 NG16
- 2 NG25
- 3 NG32

## Electrical connection

The type-examination tested valve solenoid is equipped with a terminal box and a type-tested cable and line entry. The connection is polarity-independent.

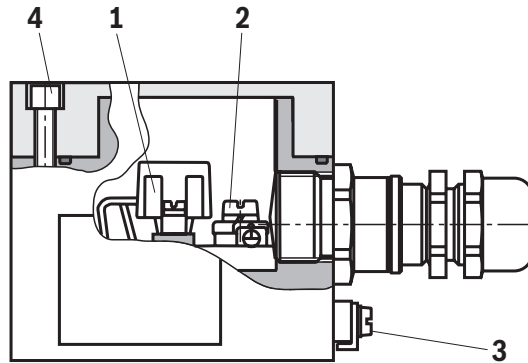

### Properties of the connection terminals and mounting elements

Position	Function	Connectable line cross-section
1	Operating voltage connection	single-wire 0.75 ... 2.5 mm <sup>2</sup> finely stranded 0.75 ... 1.5 mm <sup>2</sup>
2	Connection for protective grounding conductor	single-wire max. 2.5 mm <sup>2</sup> finely stranded max. 1.5 mm <sup>2</sup>
3	Connection for potential equalization conductor	single-wire 4 ... 6 mm <sup>2</sup> finely stranded min. 4 mm <sup>2</sup>
4	Screws for cover	–

Cable gland		
Line diameter	mm	6.1 ... 11.7
Sealing		Outer sheath sealing

Connection line		
Line type		<b>non-armored</b> cables and lines (outer sheath sealing)
Temperature range	°C	-20 ... > +110



#### Notice:

Only use finely stranded conductors if they have pressed-on wire end ferrules.

## Electrical connection

### Circuit diagram

Direct voltage, polarity-independent

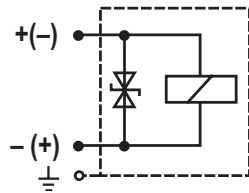

### Over-current fuse and switch-off voltage peaks

Voltage data in the valve type code	Nominal voltage valve solenoid	Rated current Valve solenoid	Recommended pre-fuse Characteristics medium time-lag according to DIN 41571	Maximum voltage value when switching off	Interference protection circuit
G24	24 VDC	0.542 ADC	630 mA	-90 V	Suppressor diode bi-directional

#### Notice:

A fuse which corresponds to the rated current according to DIN 41571 and EN / IEC 60127 has to be connected upstream of every valve solenoid (max.  $3 \times I_{\text{rated}}$ ).

The shut-off threshold of the fuse has to match the prospective short-circuit current of the supply source.

The short-circuit current of the supply source to be expected may amount to a maximum of 1500 A.

This fuse may only be installed outside the potentially explosive atmospheres or must be of an explosion-proof design. When inductivities are switched off, voltage peaks result which may cause faults in the connected control electronics.

## Further information

- ▶ Subplates
- ▶ Hydraulic fluids on mineral oil basis
- ▶ Environmentally compatible hydraulic fluids
- ▶ Flame-resistant hydraulic fluids - containing water (HFAE, HFAS, HFB, HFC)
- ▶ Directional spool valves, pilot-operated, with electro-hydraulic actuation
- ▶ Selection of filters
- ▶ Information on available spare parts

Data sheet 45100

Data sheet 90220

Data sheet 90221

Data sheet 90223

Operating instructions 24751-XD-B

[www.boschrexroth.com/filter](http://www.boschrexroth.com/filter)

[www.boschrexroth.com/spc](http://www.boschrexroth.com/spc)

Bosch Rexroth AG  
 Industrial Hydraulics  
 Zum Eisengießer 1  
 97816 Lohr am Main, Germany  
 Phone +49 (0) 93 52/40 30 20  
[my.support@boschrexroth.de](mailto:my.support@boschrexroth.de)  
[www.boschrexroth.de](http://www.boschrexroth.de)

© All rights reserved to Bosch Rexroth AG, also regarding any disposal, exploitation, reproduction, editing, distribution, as well as in the event of applications for industrial property rights.  
 The data specified above only serve to describe the product. No statements concerning a certain condition or suitability for a certain application can be derived from our information. The information given does not release the user from the obligation of own judgment and verification.  
 It must be remembered that our products are subject to a natural process of wear and aging.